

where design meets manufacturing

## Bends and Twists

Waveguide bends part number generation for quote and ordering purposes on page 2, twists on page 3

WG14 Large radius 'E' Bend with straights and cast bends at the flanges

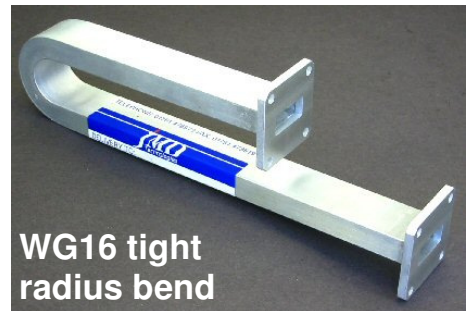
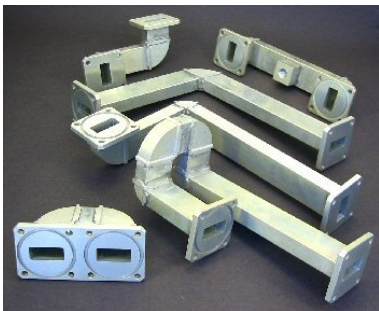
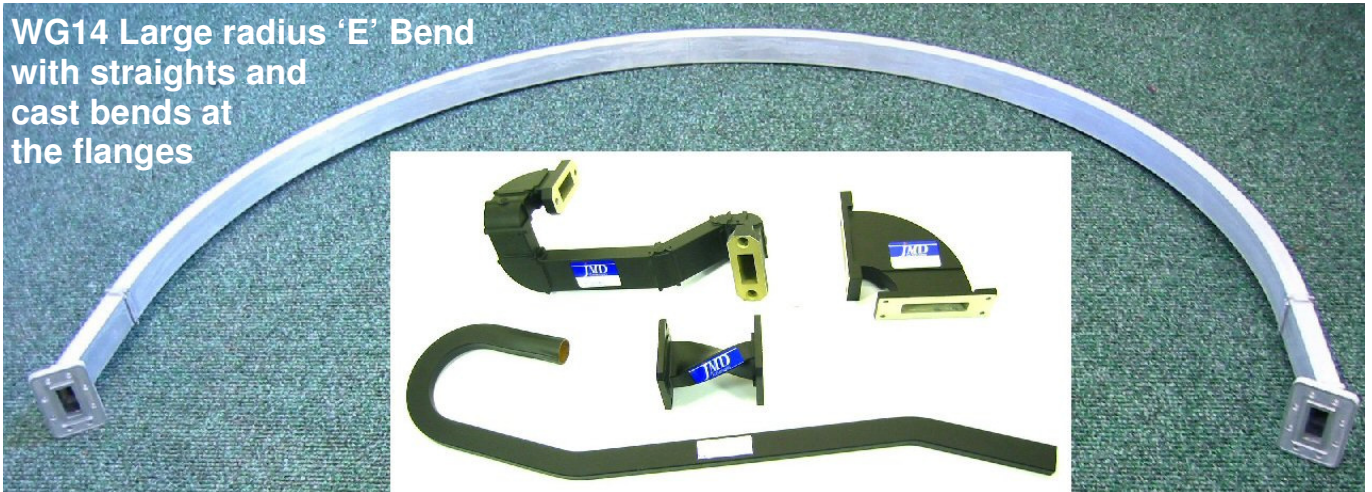

A1 Microwave's Waveguide Division manufactures waveguide assemblies comprising multiple bends and twists using cast, machined or bent waveguide from WG 6 ( WR 650 ) to WG 22 ( WR 28 )

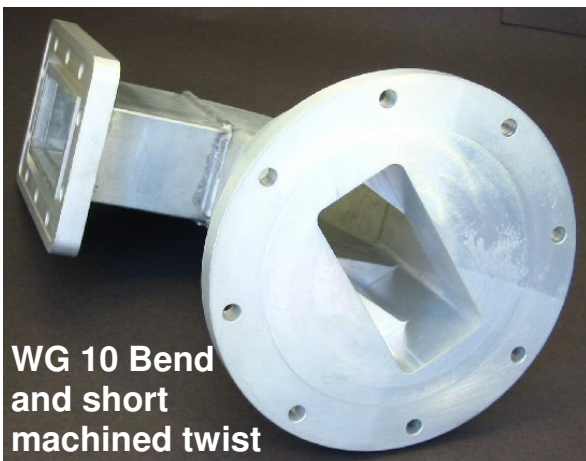

**A1 Microwave, Waveguide Division**  
**Precision waveguide components. Build to print manufacturing.**

where design meets manufacturing

## Waveguide bends

Waveguide bends part number generation for quote and ordering purposes

Flange code, standard is plain

WR code			UD		PD		CF		CG		UB		PB		UA		PA		UG
Waveguide definition	Typical operating range (GHz)	Internal dimensions (mm)	Rectangular Plain	O-ring grooved	Rectangular Plain	O-ring grooved	Number of holes	Square Plain	O-ring grooved	Round Plain	O-ring grooved	Number of holes	Provide full UG number on order						
WG	R	WR	6 / 8 / 10 Hole	6 / 8 / 10 Hole	6 / 8 / 10 Hole	6 / 8 / 10 Hole	4 Hole	6 / 8 Hole	6 / 8 Hole	Number of holes	Number of holes	Number of holes							
6	14	650	1.1	1.7	165.100	82.550	UDR 14	PDR 14	CPR 650F	CPR 650G	10								
8	22	430	1.7	2.6	109.220	54.610	UDR 22	PDR 22	CPR 430F	CPR 430G	10								
9A	26	340	2.2	3.3	86.360	43.180	UDR 26	PDR 26	CPR 340F	CPR 340G	10								
10	32	284	2.6	3.95	72.140	34.040	UDR 32	PDR 32	CPR 284F	CPR 284G	10				UAR 32	PAR 21	8		
11A	40	229	3.3	4.9	58.170	29.083	UDR 40	PDR 40	CPR 229F	CPR 229G	10				UAR 40	PAR 40	8		
12	48	187	3.9	6.0	47.550	22.149	UDR 48	PDR 48	CPR 187F	CPR 187G	8				UAR 48	PAR 48	8		
13	58	159	4.6	7.1	40.390	20.193	UDR 58	PDR 58	CPR 159F	CPR 159G	8				UAR 58	PAR 58	6		
14	70	137	5.3	8.2	34.850	15.799	UDR 70	PDR 70	CPR 137F	CPR 137G	8				UAR 70	PAR 70	6		
15	84	112	6.6	10.0	28.499	12.624	UDR 84	PDR 84	CPR 112F	CPR 112G	6	UBR 84	PBR 84						
16	100	90	8.2	12.5	22.860	10.160	UDR 100	PDR 100	CPR 90F	CPR 90G	6	UBR 100	PBR 100						
17	120	75	9.8	15.0	19.050	9.525	UDR 120	PDR 120				UBR 120	PBR 120						
18	140	62	11.9	18.0	15.799	7.899	UDR 140	PDR 140				UBR 140	PBR 140						
19	180	51	14.5	22.0	12.954	6.477						UBR 180	PBR 180						
20	220	42	17.6	26.7	10.668	4.318						UBR 220	PBR 220						
21	260	34	21.7	33.0	8.636	4.318						UBR 260	PBR 260						
22	320	28	26.4	40.0	7.112	3.556						UBR 320	PBR 320						

**Bend code**

BH for H plane bend  
 BE for E plane bend

**Material code, standard is Aluminium**

A for Aluminium  
 B for Brass  
 C for Copper

**Paint finish code, standard is Black**

B for Matt black epoxy 80/161 (DTD 5555A) Scheme III  
 W for Gloss white two pack polyurethane  
 G for NATO Green Infra Red Reflective Matt  
 U for passivated unpainted

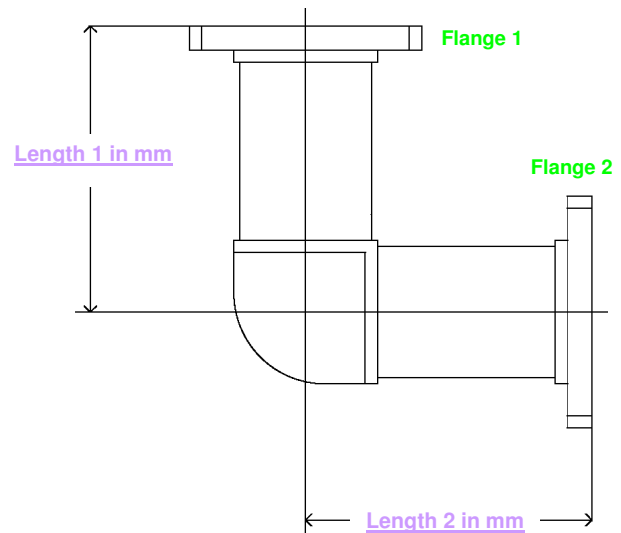

**Part number is made up from the following information**

“Bend code” - “WR code” - “Flange code 1” / “Flange code 2” - “Length 1 in mm” / “Length 2 in mm” - “Material code” - “Paint finish code”

Example : BE-137-UD/PD-100/150-A-B

for an E plane bend in WR137 with UDR 70 + PDR 70 flanges 100 + 150 mm long in Aluminium and painted black

**A1 Microwave, Waveguide Division**  
 Precision waveguide components. Build to print manufacturing.

where design meets manufacturing

## Waveguide twists

Waveguide twists part number generation for quote and ordering purposes

Flange code, standard is plain

WR code			UD		PD		CF		CG		UB		PB		UA		PA		UG
Waveguide definition	Typical operating range (GHz)	Internal dimensions (mm)	Rectangular Plain	O-ring grooved	Rectangular Plain	O-ring grooved	Number of holes	Square Plain	O-ring grooved	Round Plain	O-ring grooved	Number of holes	Provide full UG number on order						
WG	R	WR	6 / 8 / 10 Hole	6 / 8 / 10 Hole	6 / 8 / 10 Hole	6 / 8 / 10 Hole	4 Hole	6 / 8 Hole	Number of holes	Number of holes	Number of holes	Number of holes							
6	14	650	1.1	1.7	165.100	82.550	UDR 14	PDR 14	CPR 650F	CPR 650G	10								
8	22	430	1.7	2.6	109.220	54.610	UDR 22	PDR 22	CPR 430F	CPR 430G	10								
9A	26	340	2.2	3.3	86.360	43.180	UDR 26	PDR 26	CPR 340F	CPR 340G	10								
10	32	284	2.6	3.95	72.140	34.040	UDR 32	PDR 32	CPR 284F	CPR 284G	10			UAR 32	PAR 21	8			
11A	40	229	3.3	4.9	58.170	29.083	UDR 40	PDR 40	CPR 229F	CPR 229G	10			UAR 40	PAR 40	8			
12	48	187	3.9	6.0	47.550	22.149	UDR 48	PDR 48	CPR 187F	CPR 187G	8			UAR 48	PAR 48	8			
13	58	159	4.6	7.1	40.390	20.193	UDR 58	PDR 58	CPR 159F	CPR 159G	8			UAR 58	PAR 58	6			
14	70	137	5.3	8.2	34.850	15.799	UDR 70	PDR 70	CPR 137F	CPR 137G	8			UAR 70	PAR 70	6			
15	84	112	6.6	10.0	28.499	12.624	UDR 84	PDR 84	CPR 112F	CPR 112G	6	UBR 84	PBR 84						
16	100	90	8.2	12.5	22.860	10.160	UDR 100	PDR 100	CPR 90F	CPR 90G	6	UBR 100	PBR 100						
17	120	75	9.8	15.0	19.050	9.525	UDR 120	PDR 120				UBR 120	PBR 120						
18	140	62	11.9	18.0	15.799	7.899	UDR 140	PDR 140				UBR 140	PBR 140						
19	180	51	14.5	22.0	12.954	6.477						UBR 180	PBR 180						
20	220	42	17.6	26.7	10.668	4.318						UBR 220	PBR 220						
21	260	34	21.7	33.0	8.636	4.318						UBR 260	PBR 260						
22	320	28	26.4	40.0	7.112	3.556						UBR 320	PBR 320						

Twist code, standard is right handed, as shown in drawing >

TR for right hand  
 TL for left hand

Material code, standard is Aluminium

A for Aluminium  
 B for Brass  
 C for Copper

Paint finish code, standard is Black

B for Matt black epoxy 80/161 (DTD 5555A) Scheme III  
 W for Gloss white two pack polyurethane  
 G for NATO Green Infra Red Reflective Matt  
 U for passivated unpainted

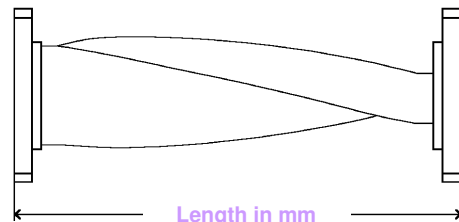

Use "0" length for twist plates and specify frequency range

For WR 650, 430, 340 and 284 only twist plates are available

Part number is made up from the following information

"Twist code" - angle in degrees - "WR code" - "Flange code" / "Flange code" - "Length in mm" - "Material code" - "Paint finish code"

Example : TR-090-137-UD/PD-100-A-B

for a right hand 90 degree twist in WR137 with UDR 70 + PDR 70 flanges 100 mm long in Aluminium and painted black

**A1 Microwave, Waveguide Division**  
**Precision waveguide components. Build to print manufacturing.**

# A1 Microwave

Web: <http://www.A1Microwave.com>

Email: [sales@A1Microwave.com](mailto:sales@A1Microwave.com)



*where design meets manufacturing*

A1 Microwave, is internationally recognised for innovative design and manufacturing procedures.

The Company acquired JMD Technologies in 2010 which had an established credibility in Precision Waveguide Component and Sub-Assembly production - WG 6 ( WR 650 ) to WG 22 ( WR 28 ), and has been manufacturing since 1990.

We supply specialist, non-standard items to the Defence, Aerospace, Marine, Satellite Communications, Commercial and High Power segments of the Markets.

Our Expertise covers 'Build to Print' from customers drawings through Design, Manufacture & Test up to 50 GHz.

Our Designs are appropriate to the clients individual specification.

Production is in a tightly controlled environment, utilising the latest CNC Milling and Turning facilities, Bending, Brazing and Assembly.

A1 Microwave have invested in our Quality Control Systems, equipment and procedures so as to meet the most rigorous of customer requirements, as part of this process we operate an ISO 9001:2000 Certified QA system.

We are always pleased to advise on and discuss your requirements.

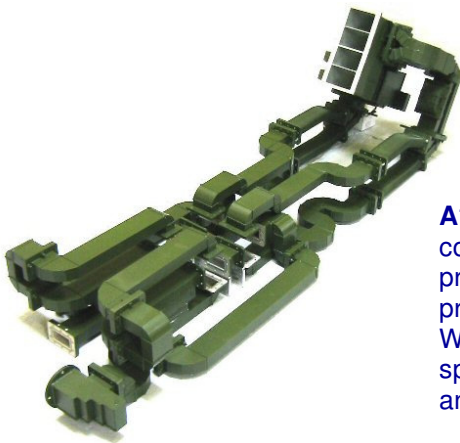

Using the latest in CNC Machines, of which the majority have four axis capability, **A1 Microwave's Waveguide Division** possesses a sophisticated and flexible facility, which is able to address the most complex, high tolerance components, manufactured to the finest tolerances.

**A1 Microwave Ltd** is a forward looking company with an active development programme and proven track record in product excellence. We are committed to producing a specific response to your requirements and look forward to hearing from you.



Our expertise includes brazing of Aluminium and Copper based Alloys, which allow complex components and sub-assemblies to be produced to exceptionally high standards.

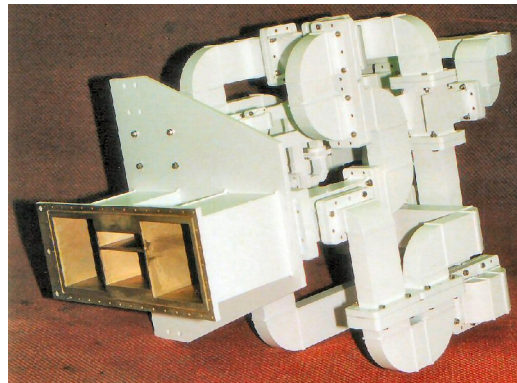

Our Brazing department has been established to meet BS1723 and MIL-B-7883 standards, thereby allowing the most demanding requirements to be fulfilled.

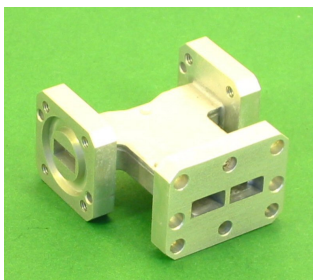

Our CNC milling and Turning facilities Are capable of producing complex, high tolerance components which when combined with our precision Waveguide Bending capability offer a versatile and sophisticated manufacturing facility.

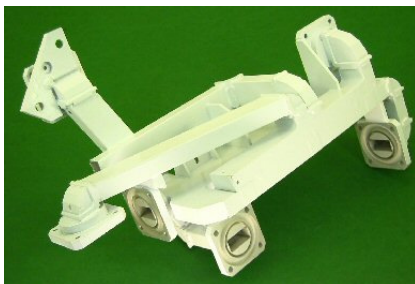

**A1 Microwave, Waveguide Division**  
**Precision waveguide components. Build to print manufacturing.**